

Flower Pot



Specification

12 Faces Colours Available - Natural Gray Concrete or Integral Pigment Colour as per client specification
 Drainage Hole Options - No drainage hole (for interior applications) or approximate 1 inch hole Optional - Bituminous Sealer (suggested for interior applications)
 Manufactured from M-30 grade concrete using a combination of vibro-compaction and spinning process

Overall Height - 18 inches (457 mm),
 Top Max Width = 24" (610 mm), Bottom Max Width = 9.5 inches (241 mm)



Specification

Colours Available - Natural Gray Concrete or Integral Pigment Colour as per client specification
 Drainage Hole Options - No drainage hole (for interior applications) or approximate 1 inch hole Optional - Bituminous Sealer (suggested for interior applications)
 Manufactured from M-30 grade concrete using a combination of vibro-compaction and spinning process

Overall Height - 15 inches (380 mm), Top Max Width = 20" (508 mm), Bottom Max Width = 8 inches (203 mm)

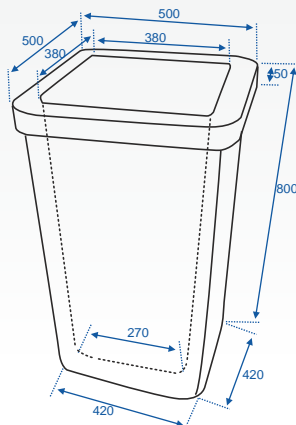

Specification

- Suitably reinforced for long use and to prevent damage during transportation & handling
- The outside surface of the dust bin has an exposed aggregate surface of approved marble chips combination
- Each bin has a hole of 50mm dia. at the bottom for drainage.